



## Electric Butterfly Valve

# Instruction Manual

- Please read this instruction manual carefully before installation and use.
- Retain this manual for future reference.
- Ensure proper use of the product by thoroughly understanding the contents of this manual.

# Contents

<b>Electrical Wiring Diagram</b> .....	1
<b>Valve Body Assembly Drawing</b> .....	3
<b>Installation Steps of Electric Butterfly Valve</b> .....	5
<b>Cautions Before Installation</b> .....	5
<b>Installation Steps</b> .....	6
<b>Product Installation</b> .....	8
<b>Common Faults and Solutions</b> .....	9

# Electrical Wiring Diagram

Control Circuit	Model Code	Circuit Diagram
<p>Switching Action Mode: Switching operations (open/close) are achieved via AC switching signals, and a set of active position signals indicating fully open/fully closed status are output.</p>	S	
<p>Switching Action Mode: Outputs passive contact signals. Structure: Equipped with two intermediate position switches.</p>	MS	
<p>Switching Action Mode: Outputs 0~1000Ω feedback signal. Structure: Equipped with 500Ω or 1kΩ potentiometer.</p>	PIU	
<p>Switching Action Mode: Controls valve opening angle via switching circuit, corresponding to potentiometer resistance value, while enabling intermediate position control function. Structure: Integrated with potentiometer and intermediate position switch.</p>	SP	

# Electrical Wiring Diagram

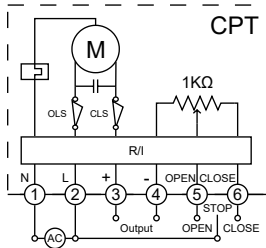
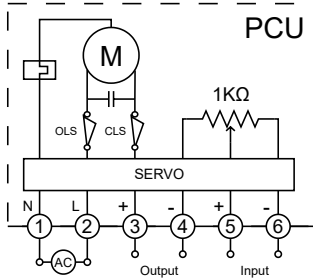
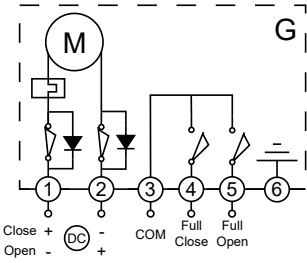
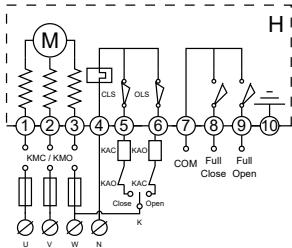
Control Circuit	Model Code	Circuit Diagram
<p>Switching Action Mode: Outputs 4~20mA valve position feedback signal. Structure: Equipped with 1kΩ potentiometer and R/I converter.</p>	<p>CPT</p>	
<p>Regulating Action Mode: Accepts 4~20mA control signal input and outputs 4~20mA valve position feedback signal. Structure: Integrated with 1kΩ potentiometer and control module (servo amplifier).</p>	<p>PCU</p>	
<p>DC switching signals are output from the circuit via an external DC power supply to control the opening/closing program, and a set of passive contact signals corresponding to fully open/fully closed positions are provided.</p>	<p>G</p>	 <p>Close +    DC - Open -    +</p>
<p>Three-phase AC switching signals are output through an external three-phase power phase-reversing circuit to control opening/closing operations, accompanied by a set of passive contact signals for fully open/fully closed position indication.</p>	<p>H</p>	

# | Valve Body Assembly Drawing

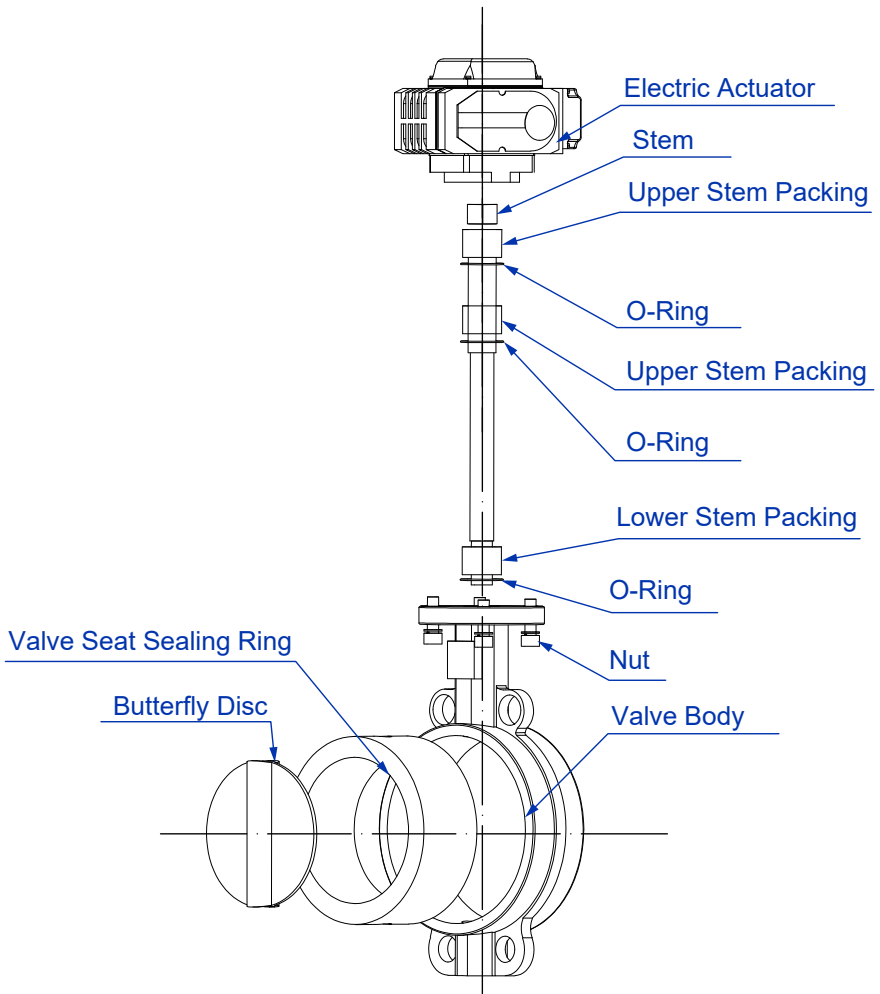

# | Valve Body Assembly Drawing

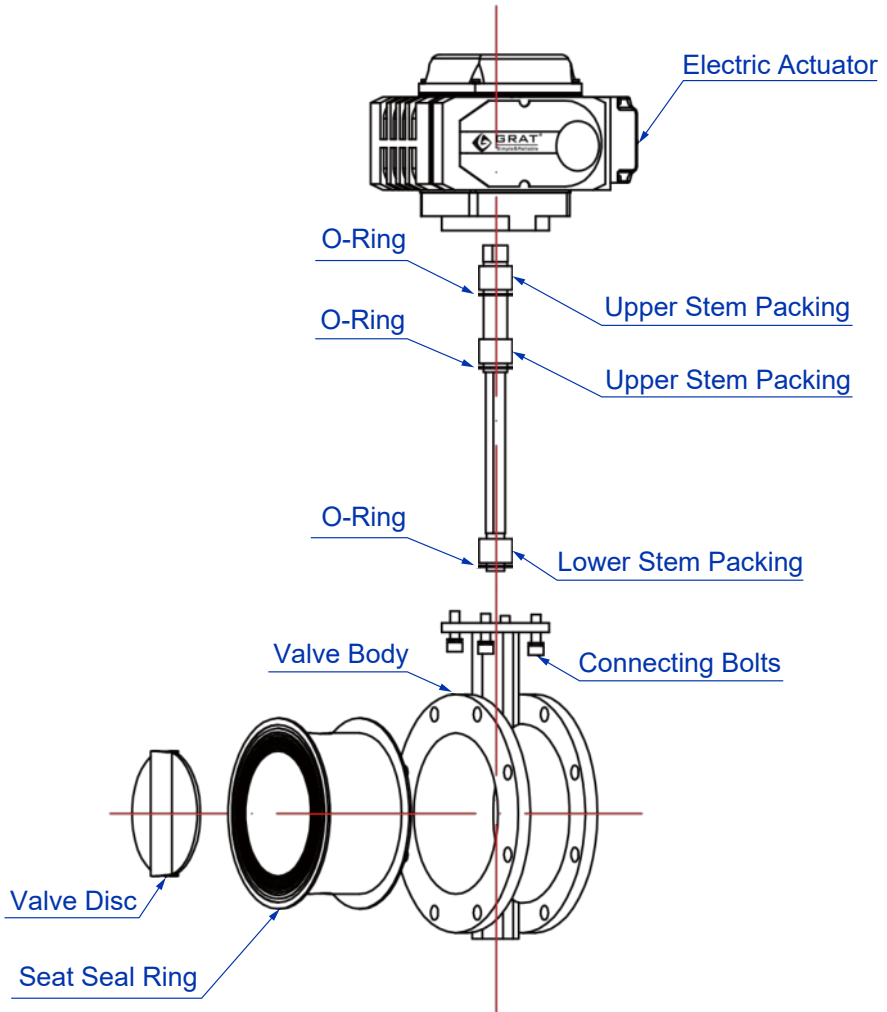

# Installation Steps of Electric Butterfly Valve

## ■ Precautions Before Installation

### Wafer Type Electric Butterfly Valve

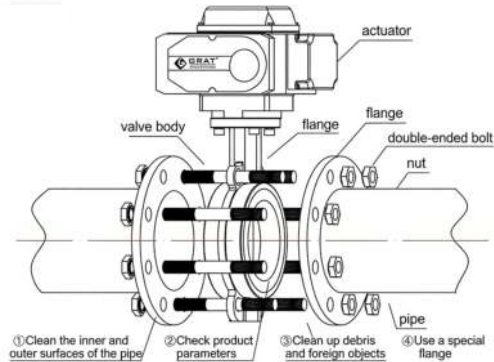

### Flanged Type Electric Butterfly Valve

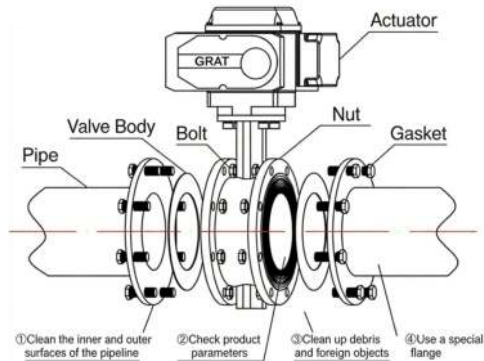

注：

1. After unpacking, the valve should be installed promptly. Do not loosen any fastening screws or nuts on the valve arbitrarily.
2. The electric butterfly valve can be installed on pipes at any angle; however, inverted installation is not recommended for ease of maintenance.
3. When installing the butterfly valve flange, ensure that the flange face is aligned with the sealing rubber, and tighten the screws evenly to achieve full contact of the sealing face. Uneven tightening of screws may cause the rubber to bulge and jam the butterfly plate, or push against the butterfly plate, resulting in leakage at the valve stem.

## ■ Installation Steps of Electric Butterfly Valve

- Place the valve between the two pre-installed flanges (for flange-type butterfly valves), pre-position the gaskets on both ends).

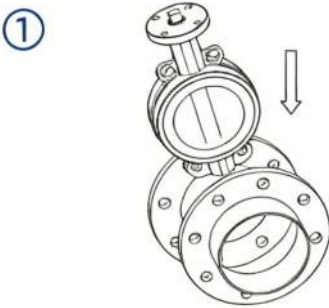

**Short Flanged Electric Ball Valve**



**Long Flanged Electric Ball Valve**

- As shown in the diagram, insert the bolts and nuts at both ends gently into the corresponding flange holes (adjust the gasket position for flange-type butterfly valves), and slightly tighten the nuts to correct the flatness of the flange faces.

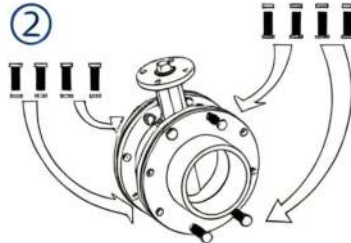
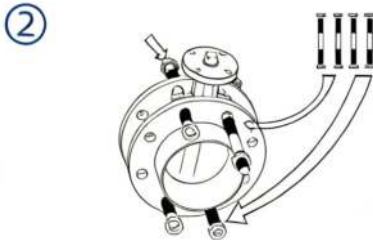

- Fix the flanges to the pipe by spot welding.

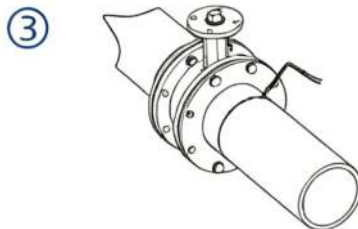
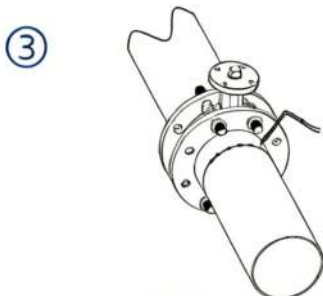

- Remove the valve from the flanges.

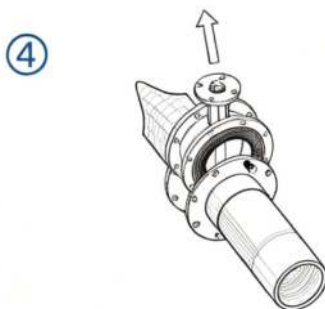
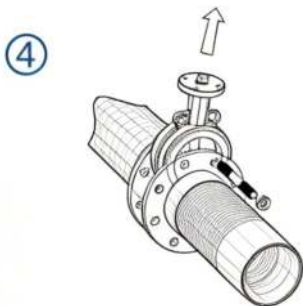

- Fully weld and fix the flanges to the pipe.

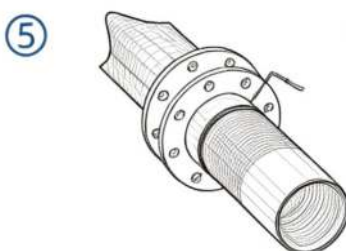
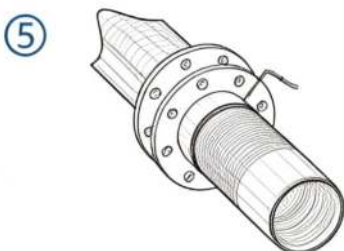

- After the weld joints cool down, reinstall the valve. Ensure there is sufficient movement space for the valve within the flanges to prevent damage to the valve, and keep the butterfly plate at a certain opening degree (install sealing gaskets for flange-type butterfly valves). Align the valve position and tighten all bolts (note: do not overtighten). Open the valve to ensure the butterfly plate can open and close freely, then slightly open the butterfly plate.

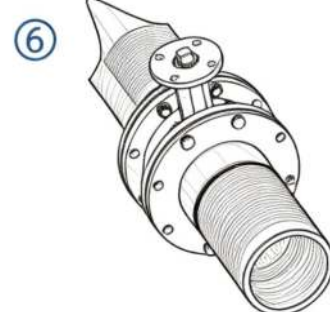
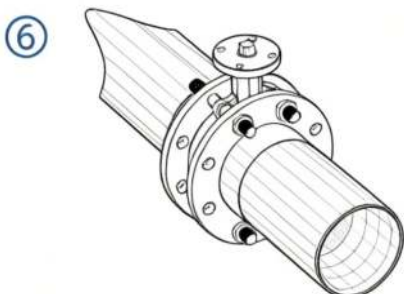

- Tighten all nuts in a crisscross and balanced manner.

⑦

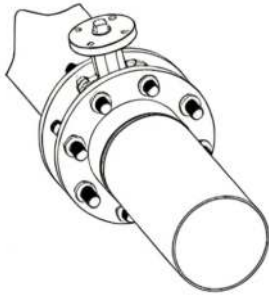

⑦

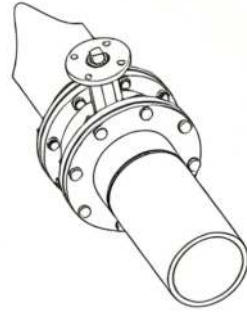

- Confirm again that the valve can open and close freely. Note: Ensure the butterfly plate does not come into contact with the pipe.

The opening and closing stroke of the electric butterfly valve's control mechanism is pre-adjusted at the factory. To prevent incorrect direction when the power is turned on, before connecting the power for the first time, the user should first manually open the valve to the half-open (50%) position, then press the electric switch. Check the switch and verify that the direction indicated on the dial matches the actual opening direction of the

## Product Installation

### Cable Installation

- Please install the electrical conduit as shown in the left diagram. During installation, note the following:

- ① Take adequate waterproof measures.
- ② The machine shall be installed higher than the electrical conduit.

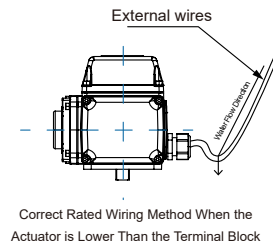
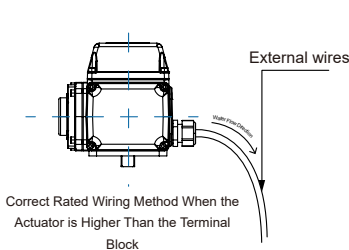

- Use an electrical conduit with an outer diameter of  $\phi 9-\phi 11$ .

As shown in the diagram below: Do not use a cable conduit that does not match the diameter of the cable gland when installing the cable. It is essential to ensure the cable interface is tightly sealed; otherwise, rainwater may seep into the machine through the cable gland and damage internal components.

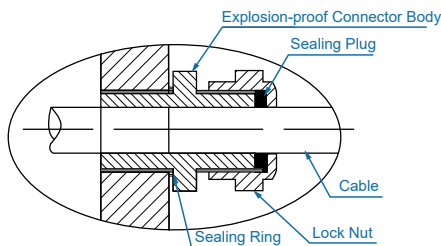

- Use shielded cables for signal wires, and do not route them in parallel with power cables.

## Common Faults and Solutions for Electric Butterfly Valves

### Causes of Seal Face Leakage in Butterfly Valves

Common Faults	Solutions
Debris is trapped between the butterfly plate and the sealing ring of the butterfly valve	Remove debris and clean the valve inner cavity
Misalignment between the butterfly plate of the butterfly valve and the sealing closure position	Adjust the limit screws of the actuator (such as the worm gear or electric actuator) to ensure the valve's correct closure position
Uneven stress on the flange bolts at both ends of the butterfly valve or insufficient compression	Check the compression force of the bolts on the mating flange surface and ensure uniform compression
Incorrect installation of the butterfly valve relative to the medium flow direction (not in accordance with requirements)	Install (rotate/press) in accordance with the direction indicated by the arrow

### Causes of Leakage at the Flanges on Both Ends of Butterfly Valves

Common Faults	Solutions
Damaged sealing gaskets on both sides Uneven compression force on the pipe	Replace the sealing gaskets
flange or insufficient compression	Tighten the flange bolts (apply force uniformly)

TEL: +86-027-60706976  
+86-027-60706977

Email: [info@gratcv.com](mailto:info@gratcv.com)

Web: <https://www.gratcv.com>

Co.Addr: No. 62, Guanggu Avenue, Wuhan, Hubei, China.

Fty.Addr: B8-3-2, OVU, Wuhan, Hubei, China.



official website